

# A 4.5 Watt Single-Ended Amplifier

---

(By the Staff of the Radiotronics Laboratory)

---

**A two-stage single-ended amplifier incorporating feedback tone-control, with some novel features and performance distinctly above the average.**

We were recently confronted by a request to design an inexpensive but good 4.5 watt amplifier for operation from a crystal pick-up and suitable for driving a wide-range loudspeaker. The type used initially was M.S.P. 12 inch woofer AU58/12P39 with 6 inch tweeter M.S.P. 20766 6PU. The design holds for any wide range loudspeaker, or, of course, for any conventional speaker with good bass response. The possible alternatives were examined carefully, since the only real snag is in the tone control. It is obvious that some very effective form of treble attenuation is required to be able to cut down the scratch level from old records. This is made more difficult by the use of an extended range loudspeaker. Experiments showed that an attenuation of well over 20 db was necessary over the range from 8000 to 15,000 c/s.

Now a two-stage amplifier with feedback is quite a straight-forward design problem, provided that the feedback is not used for tone control purposes. But when we try to incorporate feedback tone-control, although the "sine-wave" performance may appear to be satisfactory, the real shortcomings of amplifiers are shown up by "square-wave" testing.\* The initial results obtained with square-wave testing were so distressing that the alternative was seriously considered—to insert an additional stage purely for tone control purposes, without feedback, with its output connected to the input terminals of a two-stage "flat" feedback amplifier. However, there is a wide interest in two-stage amplifiers, and so we tackled the task of making the best possible two-stage amplifier, using Radiotron types 6AU6 and 6AQ5 (or 6V6-GT), and this article shows with what success.

The whole design centres around the feedback system. Feedback may be taken from two points, the 6AQ5 plate and the secondary of the output transformer. The former is simple to apply and does not introduce instability problems, but it does not reduce transformer distortion—quite a serious item in this case—and it somewhat accentuates hum. Feedback from the secondary is regarded by some as the ideal, but it cannot be used on its own with any large degree of feedback, unless very expensive output transformers are used, without danger of instability. The actual or incipient instability is largely due to the large phase shift which occurs in any transformer, between primary and secondary, as very high frequencies. Thus "negative" feedback actually becomes positive feedback at the extremes of frequency. The effects of the positive feedback at high frequencies are shown, on a square wave input of say 5000 c/s, by the extent of the overshoot and the length of time taken for the oscillation to die down.

The circuit diagram of this amplifier is shown in Fig. 1, and it will be seen that a combination of plate and secondary feedback has been used to get some of the advantages of both. The phase angle obtained is intermediate between that at the plate and on the secondary. With the tone control in the "flat" position, the total gain reduction at 1000 c/s is 9.8 times (19.8 db), this being the highest practicable value.

With the tone control in the extreme pass position there is an additional 22 db of feedback at 10,000 c/s.

\* An article on square wave testing will appear in a future issue.

The RC network shunted across the primary of the output transformer is for the purpose of reducing or eliminating the overshoot and damped high-frequency oscillation when tested with a square wave. The linearity characteristic is shown in Fig. 2, which shows that the maximum input voltage for low distortion is 0.35 V r.m.s. The linearity is quite good up to 2.5 watts in the secondary. The overload characteristic on listening test is very good and smooth, with no objectionable features.

The manufacturer's transformer efficiency rating is about 80%, and this is confirmed quite closely by the measurements on primary and secondary. The reduction in THD due to feedback averages 19.7 db between 2 and 3 watts output, a remarkably close approach to the 19.8 db applied feedback. From (C) the power output at 75 c/s is 3.1 W at 2% THD, or 1.9 W at 1%. The reduction in THD at 75 c/s due to feedback is 19.3 db at 3 watts. From (D) the power output at 5000 c/s is 2.85 W at 2% THD, or 2.05 W at 1%, while the reduction in distortion due to feedback is 15.3 db at 2 W. This slight reduction in power output for specified values of distortion at low and high frequencies due to reactive effects is, of course, to be expected, as is also the falling off in the reduction of distortion by feedback. Somewhat better values would have been expected from the use of a single secondary feedback loop, but this was ruled out as being impracticable in the case being considered.

The frequency response characteristics of the amplifier with transformer C are shown in Fig. 4. Curve 1 shows the response without feedback. Curve 2 shows the response with feedback, with the tone control flat. Curve 3 shows the effect of secondary

feedback only, by removing feedback from the plate. This gives a peak of about 3.5 db at 35,000 c/s, which would have been even higher if the total effective feedback had been increased to the same value as for Curve 2. Curve 4 shows the frequency characteristic with the tone control in the extreme bass position. Of course, by a suitable adjustment of the tone control, any intermediate characteristic between 2 and 4 may be obtained.

The response characteristics in Fig. 4 are only drawn down to the lowest frequency available from our oscillator. A special low frequency oscillator going down to about 1 c/s is under construction, and will shortly be available for our tests.

It is our opinion that no feedback amplifier should show a peak in the high frequency region higher than the level at 1000 c/s, and that there is no necessity for it to do so, since design methods are available to prevent its occurrence. By this means the amount of overshoot on square waves is reduced, although overshoot can occur even without a high frequency peak.

In view of the limited range of audible frequencies, the question might well be asked why take the trouble to measure the response up to frequencies of the order of 500 Kc/s. The reason is that there are normally peaks in response anywhere between

Fig. 1. Circuit diagram of 4.5 watt amplifier with feedback tone control. All resistors  $\frac{1}{2}$  watt unless otherwise stated. 6AQ5 plate and screen voltages to cathode 250 V. [RT28.]

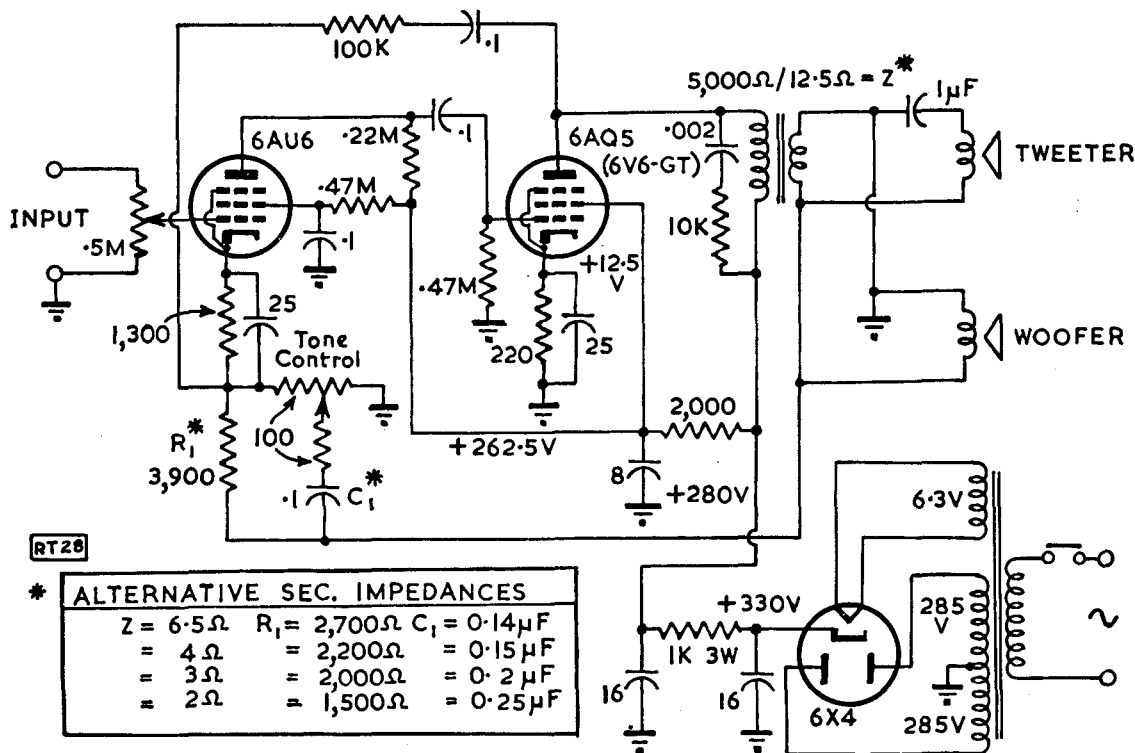

Fig. 2. Linearity characteristic using transformer C. [RT29.]

40 and 300 Kc/s, and these peaks may result in instability and "ringing" on transient waveforms. These transient waveforms occur in almost any musical reproduction. For most designers with limited equipment it is possible to use a square wave generator as a reasonably satisfactory substitute for wide-range frequency tests.

At the bass end a peak of 6.3 db at 25 c/s occurs with the tone control flat, which increases to 7.5 db when turned to "bass". This has been found to provide a small but acceptable degree of bass boosting. The response falls off quite rapidly below 25 c/s, and we have not found any need for a special rumble filter. However, if rumble is experienced, it would be very simple to decrease the extreme bass response of the pickup by reducing its load resistance.

These curves were taken without the tweeter connected, in order to make a stiffer test. The tweeter, as shown in this circuit, reduces the impedance at high frequencies and so gives better-looking curves.

Curve 2 shows an antinode at 160 Kc/s, followed by a return to the normal attenuation characteristic at 200 Kc/s. This is a function of the transformer, and occurs even without feedback (Curve 1). Transformer C was used for the curves in Figs. 4 and 5 because, of the three transformers tested, it had the best high frequency characteristics. Transformer A had a somewhat similar shape of the response characteristic, and it quite suitable for this application. But transformer B, with the primary wound in two sections, gives a series of valleys and peaks above 160 Kc/s, with a high peak at 850 Kc/s, so that this form of construction is not recommended.

The feedback versus frequency characteristics, Fig. 5, are obtained by subtracting the feedback curves in Fig. 4 from Curve 1 (without feedback). Curve 5 is for tone control flat; positive feedback occurs below 30 c/s and above 60 Kc/s. Curve 6 is for feedback from secondary only, with, of course, reduced degree of feedback—it would extend further into the positive region if the secondary feedback were increased to the same level. Curve 7 is for tone control "bass"; positive feedback occurs below 33 c/s and above 125 Kc/s. At high frequencies the peak is +20 db with the tone control "flat" and less than +7 db with tone control "bass". The former is higher than desirable in a good amplifier, but the latter is very close indeed to the figure of 6 db positive feedback usually permitted in good design (e.g., R.D.H. p. 359). The amplifier is absolutely stable under all possible conditions of load, using transformer A or C. It seems safe to say that it will be absolutely stable with any conventional transformer, or one with the secondary wound in two sections.

#### Testing with square waves.

For accurate testing with square waves it is necessary to have both a good square wave generator,

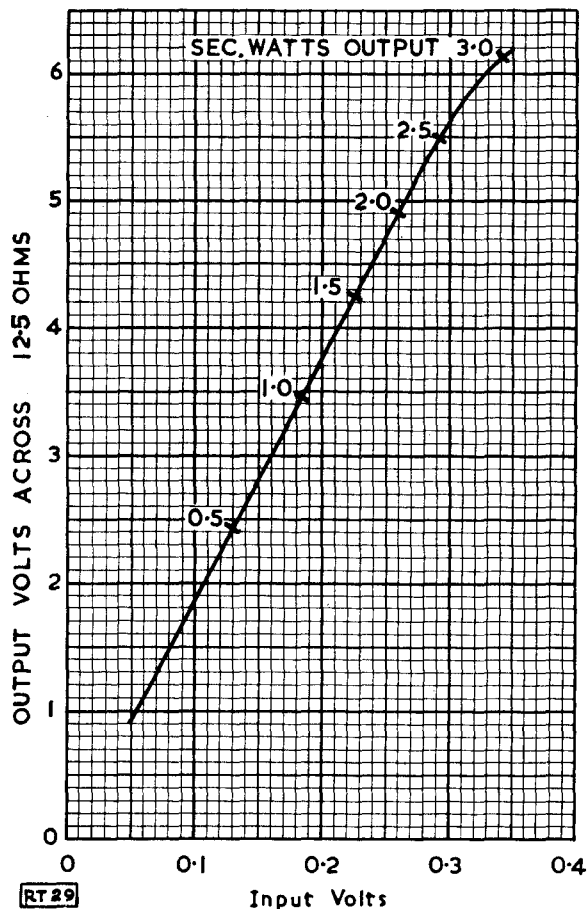

and an oscilloscope with an exceptionally good vertical amplifier—i.e., rapid uptake with no overshoot. These points will be covered in a subsequent article.

One special difficulty which was encountered in carrying out testing on this amplifier was that the setting of the input potentiometer used for the tests had a marked effect on the overshoot. It was found that when the arm was close to either limit (grid or earth) the overshoot due to the amplifier was a minimum, while when the arm was in the mid-position the overshoot was a maximum. Since this particular amplifier was intended for use with a crystal pickup with a load resistance of about 0.5 megohm, it was decided to adopt the worst possible condition with the square wave applied across a potentiometer of this value, set to the mid-point, since this would not be far from the normal operating condition. The cause of this phenomenon is apparently due, at least in part, to capacitances between the terminals of the potentiometer, since a very small capacitance (1 or 2  $\mu\mu\text{F}$ ) had a noticeable effect on the overshoot when connected between input terminal and grid.

Results obtained by tracing the square wave response with resistive load at several different frequencies are shown in Fig. 6. The 50 c/s response (A) is surprisingly good for an amplifier of this class. The 1000 c/s response in (B) and (C) shows very slight difference between these two different

transformers. The 5000 c/s response for two different transformers is shown in (D) and (E); the former is slightly overdamped while the latter shows a continued oscillation.

Similar tests on a loudspeaker load at 5000 c/s are shown in Fig. 7. Curves A and B show the

waveform with the tweeter disconnected and connected respectively, using transformer A. The results with transformer C were very similar, but the oscillation was somewhat less. Curves C and D show the effect of the RC network shunted across the transformer primary, with transformers A and C, on

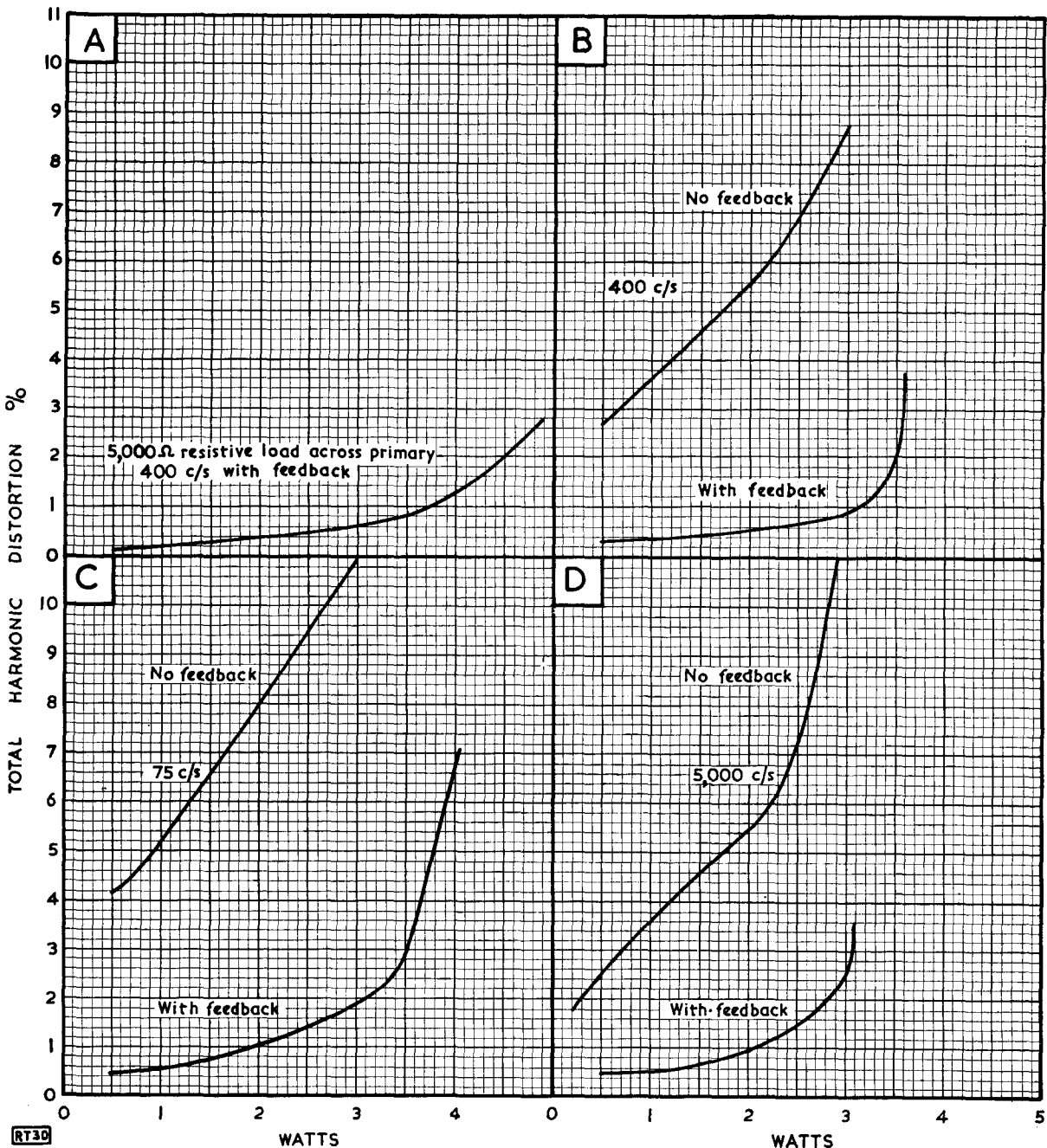

Fig. 3. Total harmonic distortion versus power output using transformer C; (A) Resistive load across primary, 400 c/s; (B), (C) and (D) Resistive load across secondary at 400, 75 and 5000 c/s respectively. [RT30.]

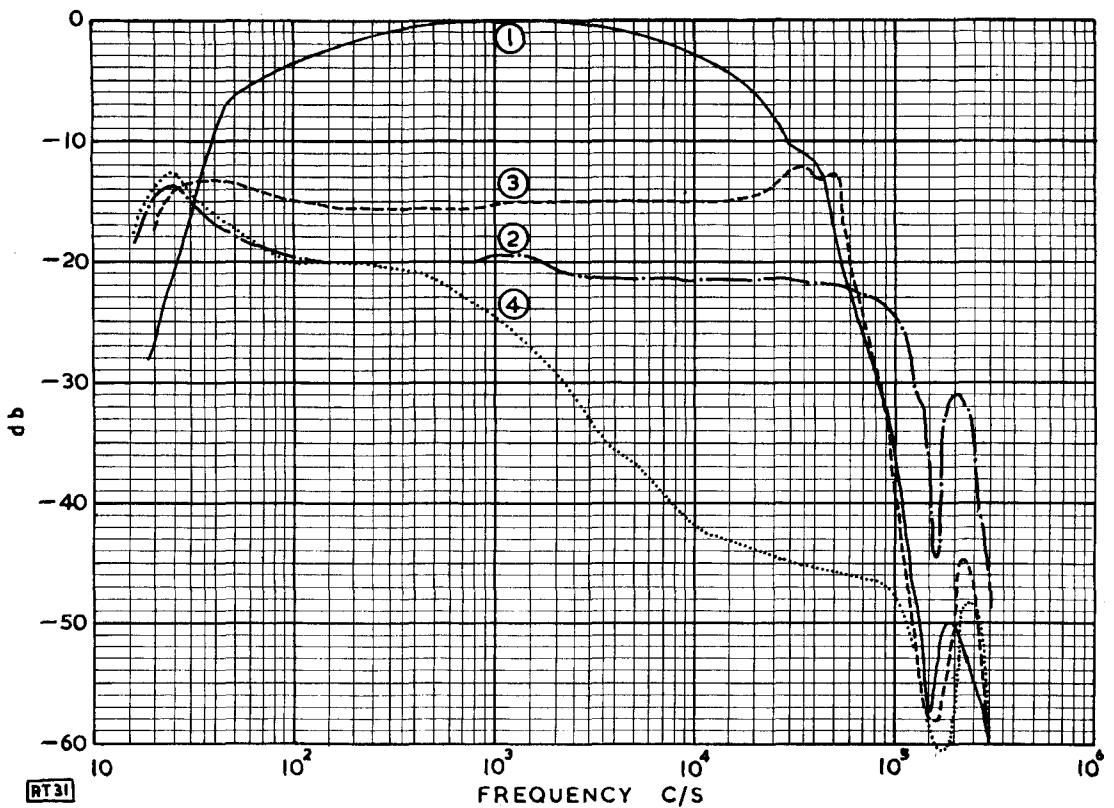

Fig. 4. Frequency response characteristics on loudspeaker load, using 12 inch speaker without tweeter. Transformer C. Curve (1) no feedback, (2) with feedback, tone control flat, (3) with secondary feedback only, (4) with normal feedback, tone control bass. [RT31.]

overload. The oscillation which occurs on one of the peaks is completely eliminated by the network; this effect only occurs on overload, and the network was incorporated principally to give a clean overload, although it also aids the general stability of the amplifier.

### Input Circuit.

The amplifier is designed for operation from a crystal pickup, and it has sufficient sensitivity to work from all the crystal pickups on the market with the exception of the Ronette Professional Model TO-284-P which, incidentally, is a particularly good pickup. The latter will not quite give enough output to overload the output valve on LP, and it is recommended that the 3900 ohm feedback resistor be increased to 5600 ohms for this application.

The pickup manufacturer's recommendations should normally be followed in the equalizer network. Pickups which are advertised as requiring no equalizing cannot be correct for both 78's and LP—if correct for LP, they need equalizing on 78's.

The amplifier may also, of course, be used with any magnetic or moving coil pickup followed by a pre-amplifier and equalizer.

### Transformers.

A. Manufacturer's Special Products TX1, 5000/12.5. This is a conventional type, with no special precautions to reduce leakage inductance.

B. This has the primary wound in two sections to reduce leakage inductance, being a design specially prepared for these tests.

C. F. G. Apthorpe, of 53 Gardere Avenue, Harbord. Type A10. Secondary wound in two sections to reduce leakage inductance. Special design for this application.

### Tabulated Performance.

	THD 1%	THD 2%
Power output—primary 400 c/s	3.7 W	4.5 W
secondary 400 c/s	3.1 W	3.5 W
Transformer efficiency 400 c/s	about 80%	
Input voltage for 3.1 watts in secondary	0.35 V r.m.s.	
Gain of amplifier at 1000 c/s without feedback	= 170 times = 44.5 db	
(from input terminals to secondary)		
Gain of amplifier at 1000 c/s with feedback	= 17.3 times = 24.7 db	
Gain reduction by feedback at 1000 c/s	19.8 db	
Reduction in total harmonic distortion due to feedback at 400 c/s	19.7 db	
Attenuation at 10,000 c/s (tone control bass)	20.5 db	
Attenuation at 15,000 c/s (tone control bass)	21.5 db	
Hum—0.008 volt across 12.5 ohms.	58 db below 3 watts.	

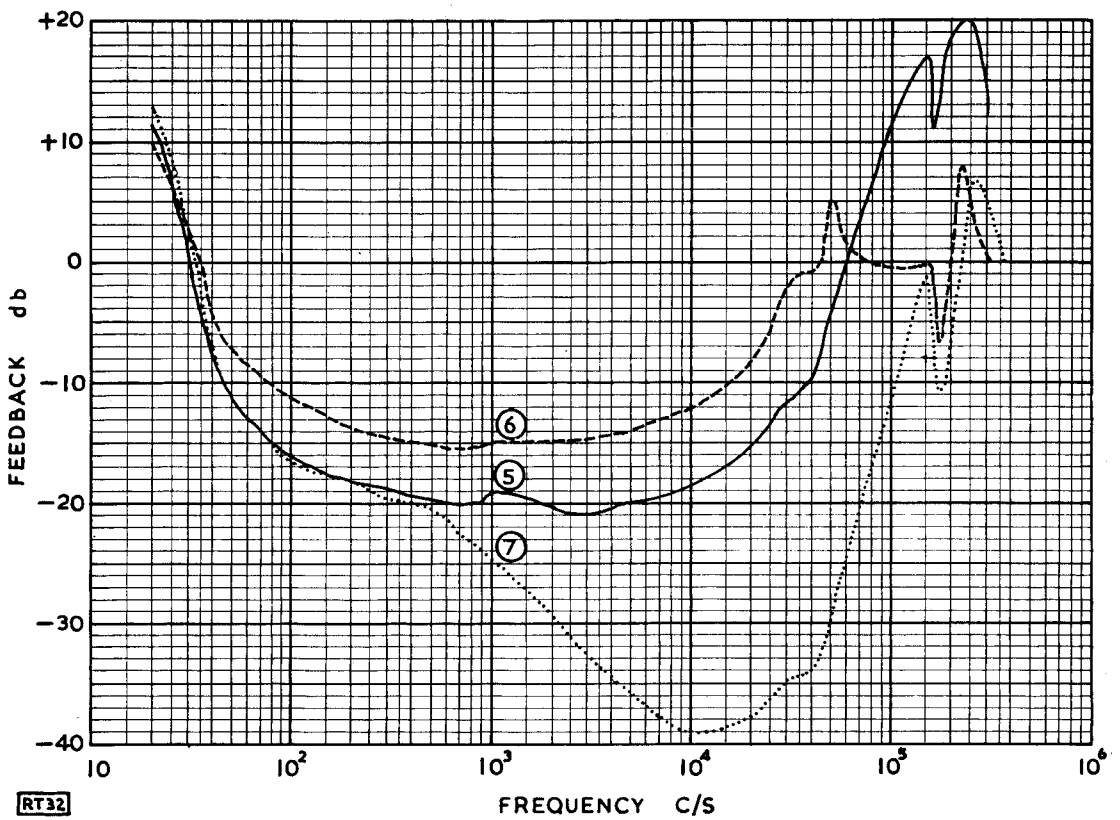

Fig. 5. Feedback versus frequency characteristics under the same conditions as in Fig. 4. Curve (5) tone control flat, (6) feedback from secondary only, (7) with normal feedback, tone control bass. [RT32.]

FIG. 6 [RT33]

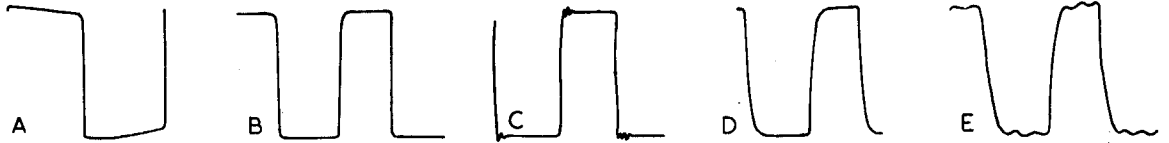

FIG. 7 [RT34]

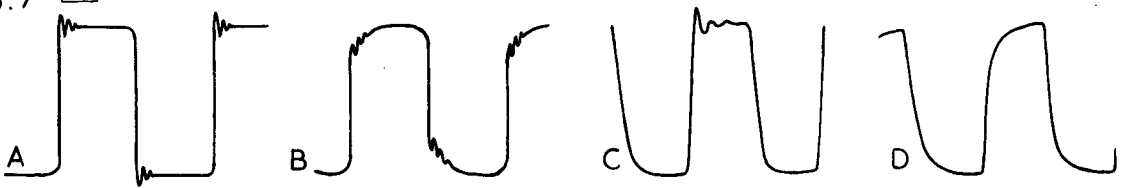

Fig. 6. Square wave response with tone control "flat", on resistive load (A) 50 c/s, transformer B; (B) 1000 c/s, transformer C; (C) 1000 c/s, transformer B; (D) 5000 c/s, transformer C; (E) 5000 c/s, transformer B. [RT33.]

Fig. 7. Square wave response with tone control "flat" on loudspeaker load at 5000 c/s (A) Transformer A with 12in. speaker load; (B) Transformer A with both 12in. speaker and tweeter load; (C) Transformer A and C on overload, without load network shunted across primary; (D) with load network shunted across primary. [RT34.]